

00-50EWNLLZ

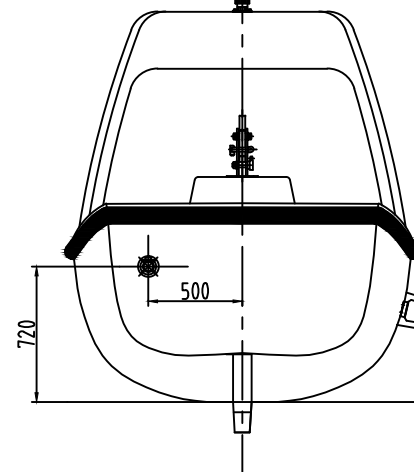
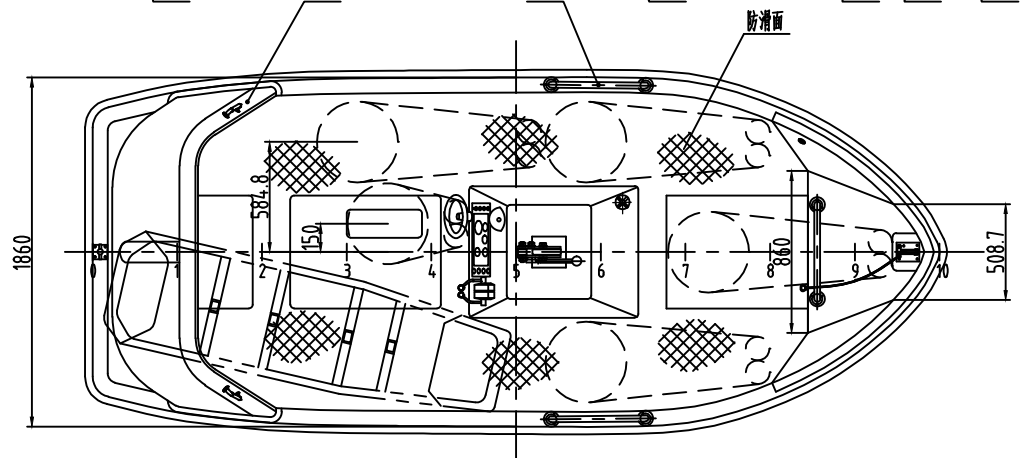
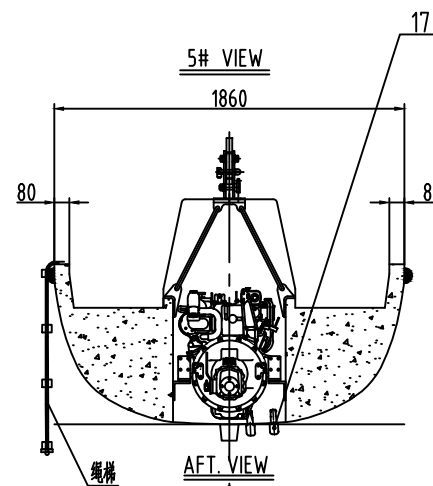
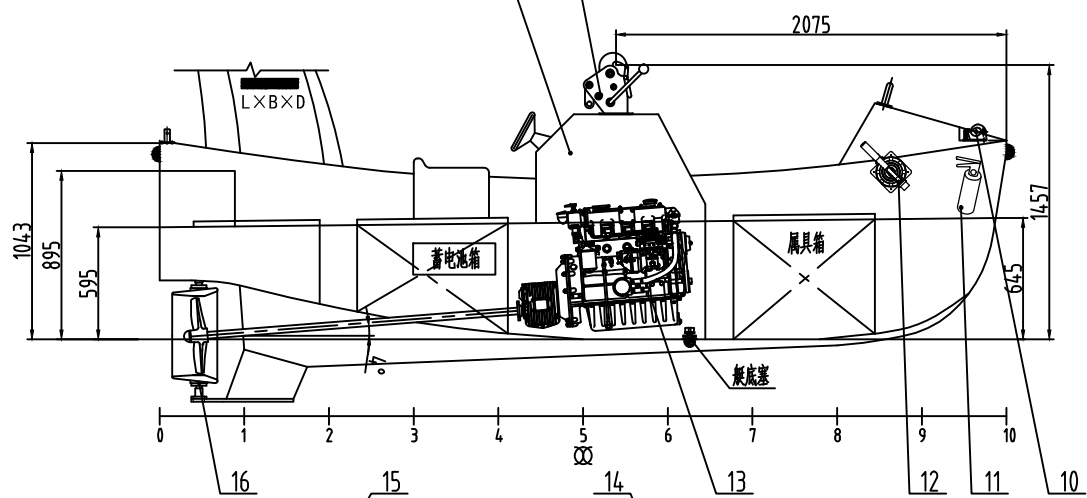
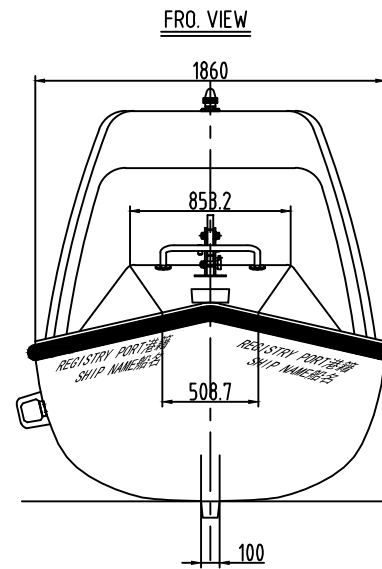
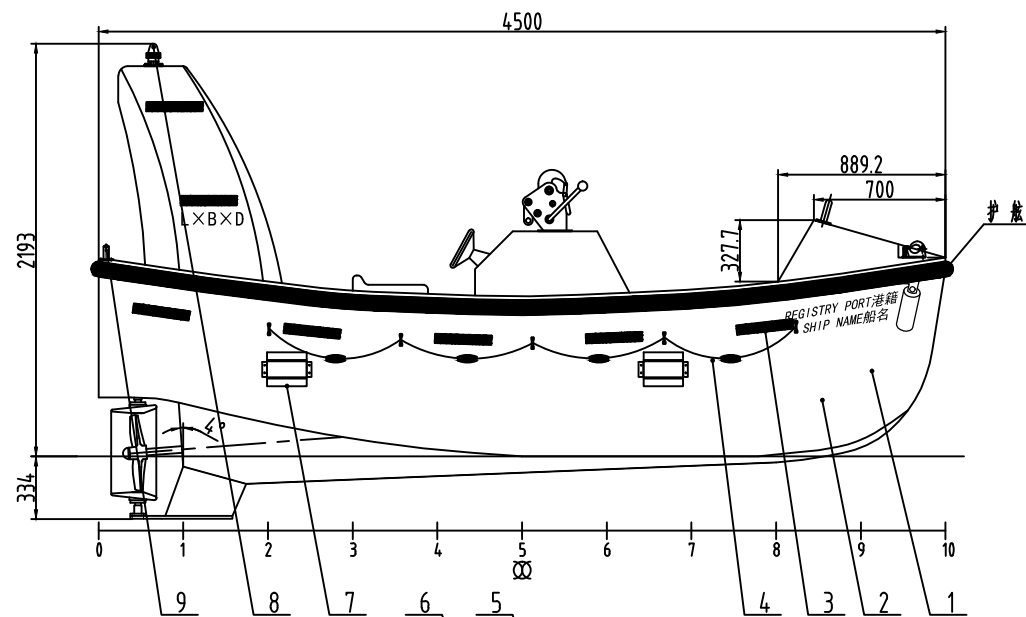

主要参数 MAIN PARAMETER

船长 Boat Length:	4.50m
型宽 Breadth:	1.86m
型深 Depth:	0.85m
额定乘员 Capacity:	6P
空艇重量 Unload Weight:	895kg
满载总重 Total Weight:	1390kg
主机 Engine:	380J-3
航速 Speed:	≥6Kn

技术要求 TECHNICAL REQUIREMENT

1、此试验大纲适用于救助艇以检查救助艇是否符合SOLAS96修正案及其MSC.216(82)、MSC.317(89)、国际救生设备规则(LSA Code)、MSC.218(82)、MSC.272(85)、MSC.320(89)修正案和IMO MSC.81(70)决议、MSC.226(82)、MSC.274(85)、MSC.321(89)、MSC.323(89)修正案

This test program is applicable to the rescue boat to check for rescue boat fully meet SOLAS96 amendment and MSC. 216 (82)、MSC.317(89), the international rules of survival equipment (LSA Code), MSC. 218 (82), MSC. 272 (85) MSC. 320 (89) amendment and IMO MSC. 81 (70), MSC. 226 (82), MSC. 274 (85), , MSC. 321 (89), MSC. 323 (89) amendment

2、本艇为左舷艇,右舷对称布置。This boat is port side, starboard symmetrical layout

序号	代号	名称	数量	材料	单件重量	总计重量	备注
17	271NM305-15-0	冷却系统 Cooling system	1	ASSEM			
16	271NM305-14-0	操舵系统 Steering system	1	ASSEM			
15	271NM305-13	扶手 Handle	2	ASSEM			
14	271NM305-12-0	扶手 Handle	5	ASSEM			
13	271NM305-11-0	动力系统 Power system	1	ASSEM			
12	271NM305-10-0	手摇泵装置 bilge pump	1	ASSEM			
11		灭火器 Fire extinguisher	1	ASSEM			
10	271NM305-09-0	舷梯装置 Painter device	1	ASSEM			
9	271NM305-08	十字桩 Bollard	1	ASSEM			
8		示位灯 Position light	1	ASSEM			
7	271NM305-07-0	滑架 Skate	2	ASSEM			
6	271NM305-06-0	机罩 Engine Cover	1	F.R.P			
5	271NM305-05-0	释放装置 Release Mechanism	1	ASSEM			
4	271NM305-04-0	救生浮索 Life line	2	ASSEM			
3	271NM305-03	反光带布置 Reflective strip	1	PVC			
2	271NM305-02	结构图 Structure Figure	1	ASSEM			
1	271NM305-01	线图 Lines Plan	1				

通用件登记
插图
校核
审核
日期

MARK		QTY		SIGNATURE		PROD. NAME		4.5米玻璃钢救助艇	
DESIGNED		MATERIAL		ASSEM		DWG. NAME		4.5M F.R.P RESCUE BOAT	
CHECKED		WEIGHT(kg)		895		PROJECTION		总布置图	
VERIFIED		SCALE		1:25		DWG. No.		GENERAL ARRANGEMENT	
DATE		2016_04		REVISION NO.		Rev01		271NM305-00	
DATE		2016_04		REVISION NO.		Rev01		DISK FILE	
DATE		2016_04		REVISION NO.		Rev01		DISK FILE	

宁波新海业救生设备有限公司
NINGBO NEW MARINE LIFESAVING EQUIPMENT CO., LTD

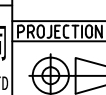

271NM305-00
总布置图 Rev01