

00-Z1EWN1Z

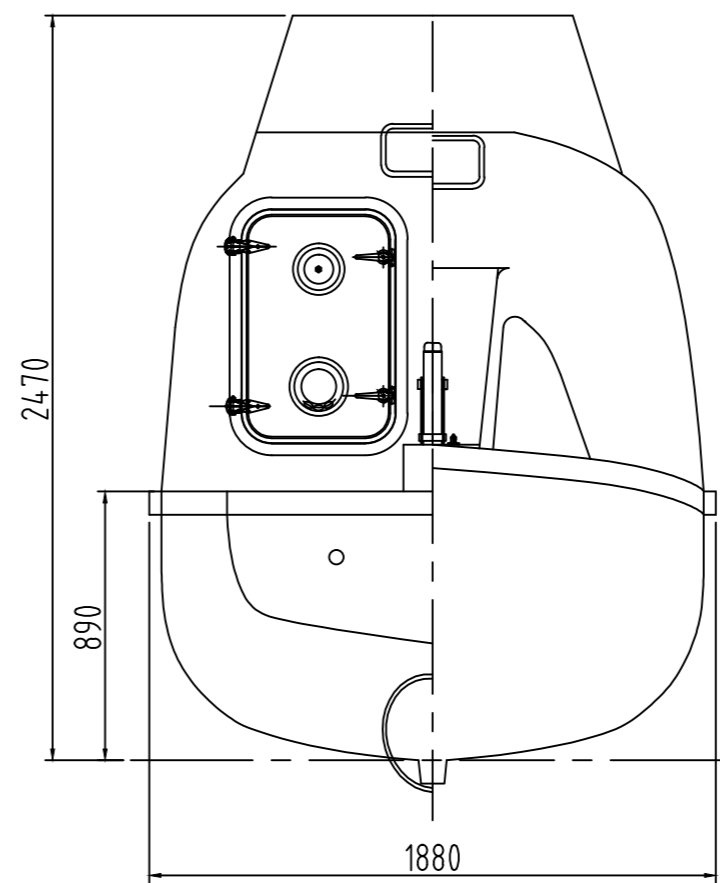

FRONT/AFT SECTION

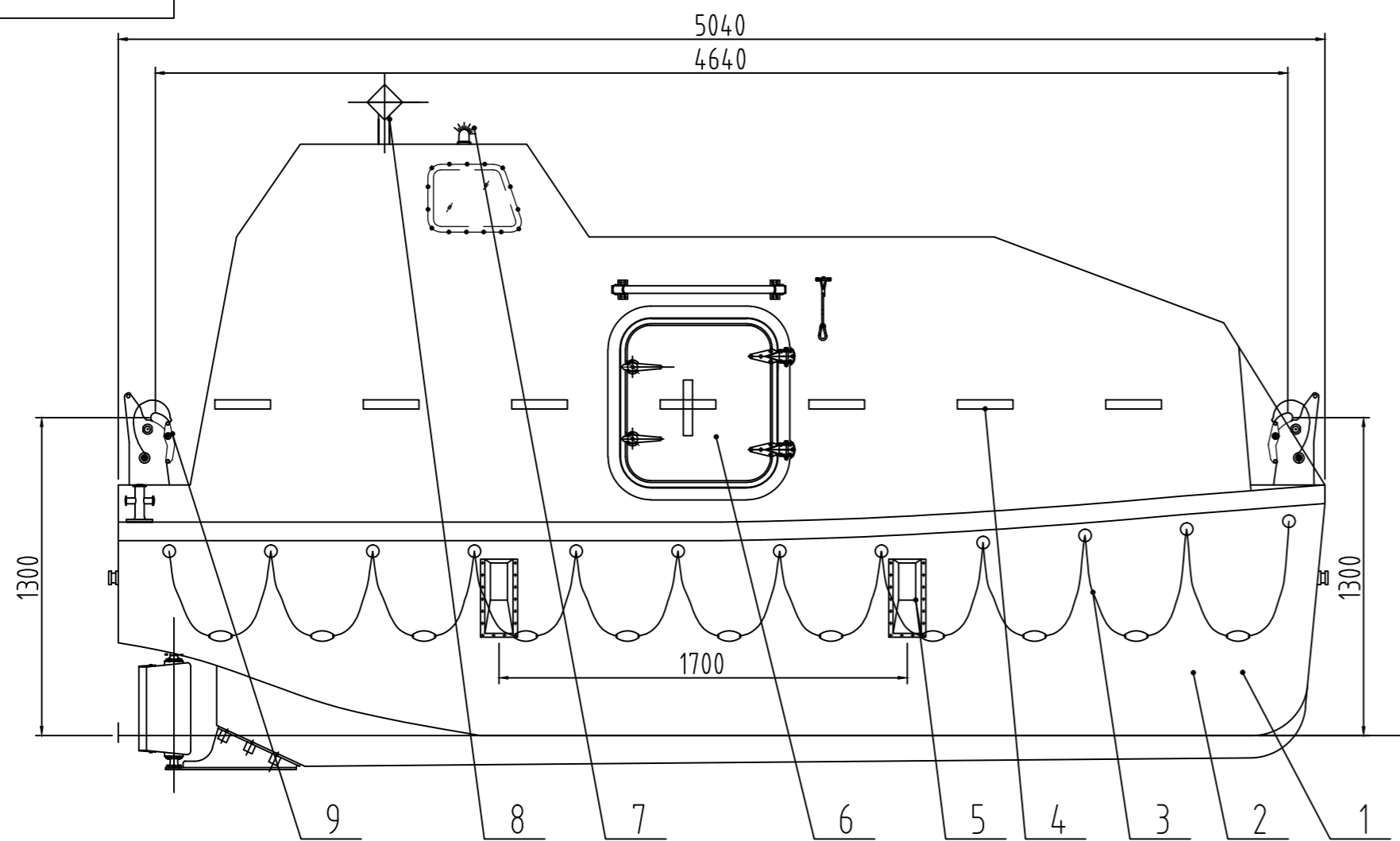
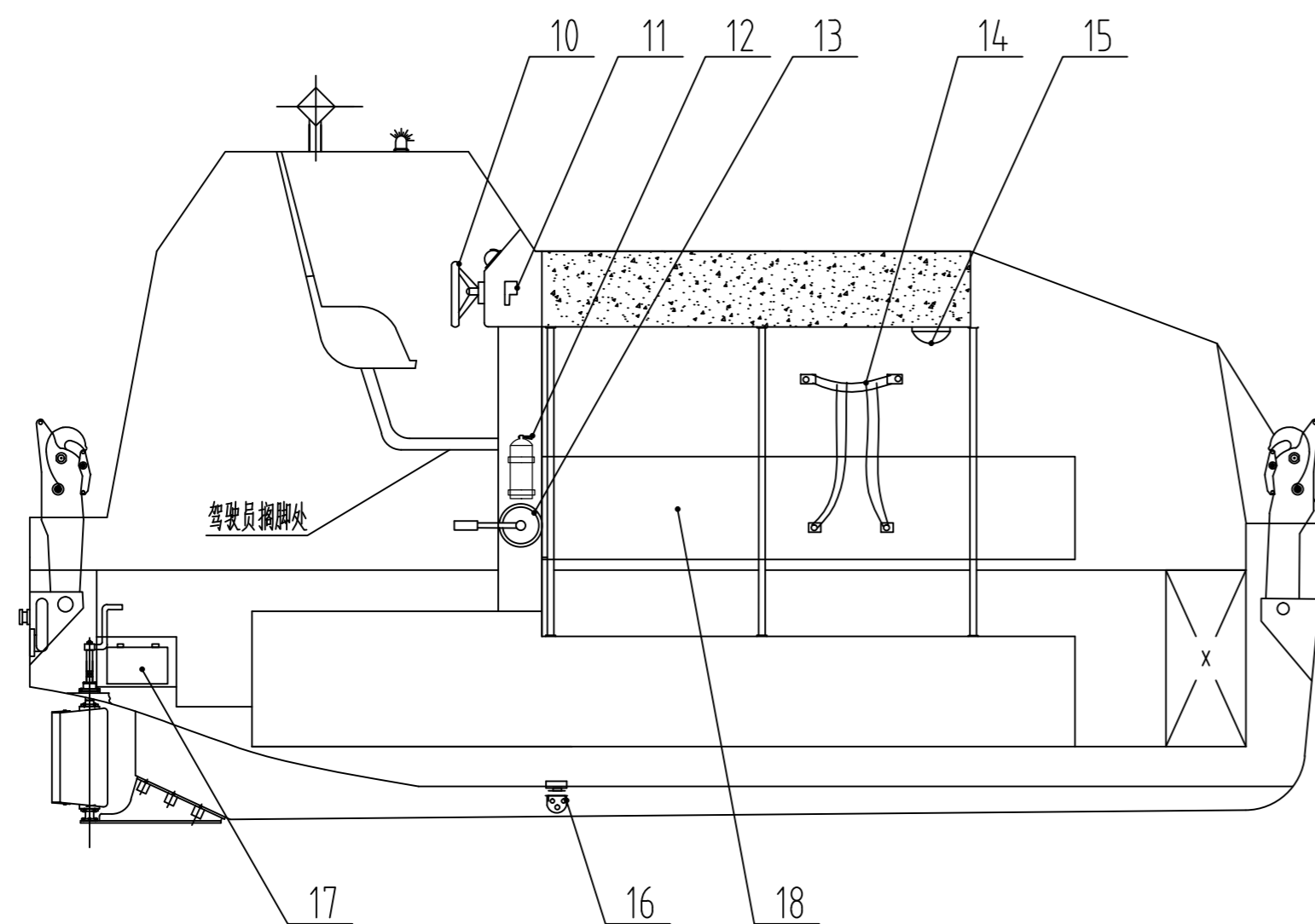

NOTE1: This boat design conforms to following standard:  
IMO MSC.48(66) LSA CODE. MSC.218(82)AND MSC.272(85);  
IMO MSC.81(70) TESTING OF LIF-SAVING APPLIANCES.  
MSC.226(82)AND MSC.274(85);

NOTE2: The engine is as main engine of the lifeboat, it is able to satisfy the 4.4.6.1 of LSA Code, having whole series of certifications.

注意1: 此艇设计根据以下标准:  
IMO MSC.48(66) LSA CODE. MSC.218(82)AND MSC.272(85);  
IMO MSC.81(70) 救生设备试验. MSC.226(82)AND MSC.274(85);  
注意2: 主机380J-3, 符合4.4.6.1, 有相应的证书。

带缆桩

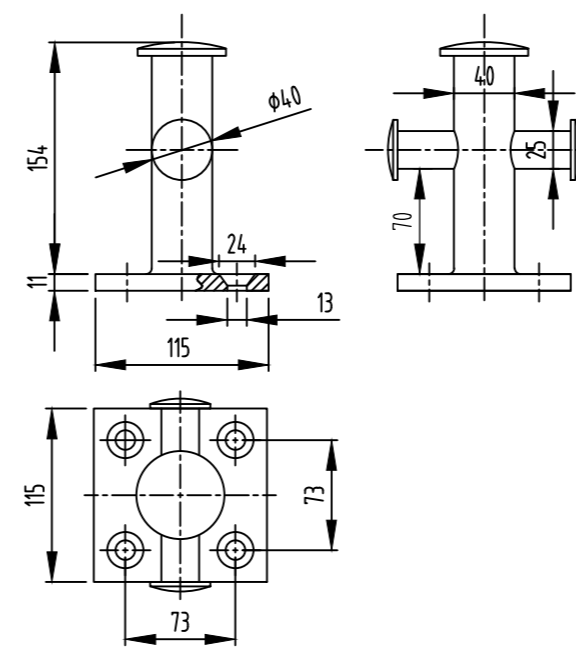

总高 total height	2.47 m
吊钩间距 hook distance	4.64 m
艏吊钩高 hook height fwd.	1.3 m
艉吊钩高 hook height aft.	1.3 m
额定乘员 persons	12 P
作救助艇时乘员 as rescue boat	6 P (人)
空艇重 craft weight	1790 kg
满载总重 total weight	2780 kg
航速 speed	--
发动机 engine	--

18	271NM312-19	靠背 Back rest	1	ASSEM			
17	271NM312-17-0	座椅 Pivot Chair	1	ASSEM			
16	271NM312-16-0	艇底塞 Drain plug	1	ASSEM			
15	271NM312-15-0	舱内灯 Cabin light	2	ASSEM			
14	271NM312-14-0	安全带 Safety Belt	1	ASSEM			
13	271NM312-13-0	手摇泵 Manual pump	1	ASSEM			
12	271NM312-12-0	灭火器 Fire Ext.	1	ASSEM			
11	271NM312-11-0	探照灯 Search Light	1	ASSEM			
10	271NM312-10-0	操纵系统 Steering System	1	ASSEM			
9	271NM312-09-0	释放机构 Release Mechanism	1	ASSEM			
8	271NM312-08	雷达反射器 Radar Reflector	1	ASSEM			
7	271NM312-07-0	示位灯 Position Light	1	ASSEM			
6	271NM312-06-0	门窗盖 Door Windows & Cover	1	ASSEM			
5	271NM312-05-0	滑架 Skate	2	ASSEM			
4	271NM312-04-0	反光带 Reflector strip	32				
3	271NM312-03	救生浮索 Lifeline	2				
2	271NM312-02-0	结构图 Structure Figure	1	ASSEM			
1	271NM312-01	线形图 Lines Plan	1				
序号	代号	名称	数量	材料	单件重量	总计重量	备注

MARK QTY SIGNATURE				PROD. NAME				5.0米全封闭救生/救助艇	
DESIGNED				MATERIAL				5.0m TOTALLY ENCLOSED LIFE/RESCUE BOAT	
CHECKED				WEIGHT(kg)				1790	
VERIFIED				SCALE				1:25	
DATE				REVISION NO.				Rev01	
DATE				2017.05					
DWG. NAME				PROJECTION				5.0米全封闭救生/救助艇	
GENERAL ARRANGEMENT				DWG. No.				271NM312-00	
NINGBO NEW MARINE LIFESAVING EQUIPMENT CO., LTD				DISK FILE				271NM312-00	

借通用件登记
插图
校核
旧底图号
签字
日期

